

*W. C. Bidwell
 1555 Abilene Dr.
 Broomfield, CO 80020*



**HOW TO USE THIS BULLET LIST
 TO SELECT A BULLET MOST SUITABLE FOR YOUR PURPOSE**

The bullet design you choose does not influence date of shipment, as each order is cut to individual specifications.

Bullets in shaded boxes are our standard bullet designs. We particularly recommend them for use for their respective purpose. The other bullets listed are more specialized.

Dark grooves in drawings are crimp grooves. Drawings are not drawn to exact scale, but are approximately actual size.

Bullet weights are only approximate, due to variance in alloy weights. Alloy weights (other than those designated linotype) are the approximate weights in the alloys in popular use at the time of their introduction.

Top figure in each box is our bullet number.

Lined base denotes gas check bullet.

NEW BULLET DESIGNS, AND DESIGNS NOT PREVIOUSLY LISTED.

Weights listed are only approximate, due to alloy variation, etc. Alloys other than linotype will weigh more.

7m/m



#289 55 grains linotype

32 ACP, especially Walther GSP-C

NOTE: #66 and #66BB (either usually sized .313" have proven successful in the GSP-C. We recommend them. The new bullets listed below may also be of interest, however, as they are variations of .38 caliber bullets that have proven successful in the S & W model 52.



#280 100 grains linotype, full wadcut-ter.



#278 100 grains linotype, similar to the .38 caliber #251, with bevel, both ends.

9 m/m



#279BB 92 grains linotype. Linford design.



#264 119 grains linotype, semi wadcut-ter. Design by Charles Derbyshire.



#275 120 grains linotype, designed by "Sleepy" Lehman.



#277 125 grains linotype, designed by John Adams.



#286 130 grains linotype, designed by Johann Roller.

38 cal



#266 75 grains linotype, designed for indoor short range (7 yards).



#274 88 grains linotype.



#272 135 grains linotype, pointed 357 magnum.



#290 #51 design with shortened nose to fit short cylinder 357 magnum revolvers.



#268BB 158 grains linotype.



#257 215 grains, lighter in linotype. Design by Eldon Carl.

41 mag

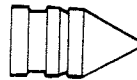

#291 Pointed nose.

44 cal



#503S 280 grains linotype, #503 with extended base band.



#271 200 gr. Linotype



#273 pointed nose.

45 ACP

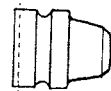

#S242 160 grains linotype.

#242 185 grains linotype.



#249 195 grains linotype, suggested by Lloyd Durst.



#265 200 grains linotype, and heavier, by extending bevel base. De- signed by John Adams. Referred to as "Adams bullet".

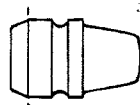

#68S #68 with extended base band to increase weight to 218 grains linotype.

#68BBS Same as #68S, with bevel base to increase weight to 226 grains linotype.

MAXI-BALL

#287 - .36 Caliber available in 4, 6 or 10 cavity molds.



#282 - .45 Caliber available in 4, 6 or 8 cavity molds.

#281 - .50 Caliber and **#283 - .54 Caliber** avail- able only in 4 cavities cut in a 6 cavity block, due to the large bullet diameter.

NOTE: Letters to the right of Box refer to types of base available.
P.B. = Plain Base ● B.B. = Bevel Base ● G.C. = Gas Check

Black Powder Percussion Rev. .31, .36 & .44 Cal.

	No. 79	P.B.
--	--------	------

.25 A.C.P.

	No. 117	P.B.
	50 gr.	

.25-20

	No. 32	G.C.
	65 gr.	

7 mm Nambu

	No. 134	P.B.
	60 gr.	

8 mm Nambu

	No. 116	P.B.
	100 gr.	

8 mm Lebel Rev.

	No. 226	P.B.
	125 gr.	

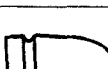

.30 Luger

	No. 93	P.B.
	90 gr.	
	No. 113	P.B.
	92 gr.	

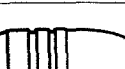

.30 M1 Carbine

	No. 250	G.C.
	113 gr.	
	No. 254	B.B.
	115 gr.	

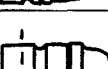
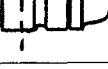

.32 Auto.

	No. 87	P.B.
	83 gr.	
	No. 252	P.B. B.B.
	98 gr.	
	No. S216	P.B.
	90 gr.	
	No. 216	P.B.
	100 gr.	

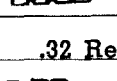

.32 Auto or Rev.

	No. S26	P.B.
	85 gr.	
	No. 26	P.B.
	98 gr.	
	No. 220	P.B.
	100 gr.	



.32 Revolver

	No. 65	P.B. B.B.
	98 gr.	
	No. 66	P.B. B.B.
	98 gr.	

.32-20

	No. 67	P.B.
	115 gr.	
	No. 89	G.C.
	115 gr.	

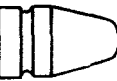





9 mm Luger

	No. 7	P.B.
	125 gr.	
	No. 115	B.B.
	125 gr.	



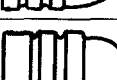

.380 Auto.

	No. S55	P.B. B.B.
	95 gr.	

.38 A.C.P. & Super

	No. 262	P.B.
	115 gr.	
	No. 81	P.B. G.C.
	130 gr.	
	No. 583	P.B.
	130 gr.	
	No. 157	P.B.
	130 gr.	
	No. 161	P.B.
	135 gr.	
	No. 55	P.B. B.B.
	135 gr.	
	No. 123	P.B.
	145 gr.	

.38 Special Auto.









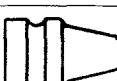

	No. 259	B.B.
	145 gr.	
	No. 244	P.B. B.B.
	146 gr.	
	No. 251	B.B.
	148 gr.	
	No. 219	B.B.
	148 gr.	
	No. 248	P.B.
	150 gr.	

.38 gold cup & Clark Conversions Usually sized .356"



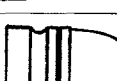











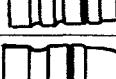
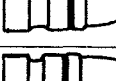
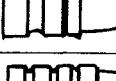

	No. 50	P.B. B.B. G.C.
	146 gr.	

Most of above bullets also available in diameters suitable for revolvers.

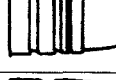
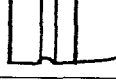



.38 Cal. Revolver

	No. 234	G.C.
	100 gr.	
	No. 154	P.B.
	110 gr.	
	No. 41	P.B. B.B.
	110 gr.	
	No. 246	P.B.
	130 gr.	
	No. 12C	P.B. G.C.
	130 gr.	
	No. 12B	P.B. G.C.
	140 gr.	
	No. 12A	P.B. G.C.
	150 gr.	
	No. 73	P.B. B.B.
	145 gr.	
	No. 63	P.B. G.C.
	145 gr.	
	No. 159	B.B.
	146 gr.	
	No. 50	P.B. B.B. G.C.
	146 gr.	
	No. 511	B.B.
	148 gr.	

.38 Cal. Rev. Cont.

	No. 9	P.B. G.C.
	150 gr.	
	No. 527	P.B. B.B.
	150 gr.	
	No. 61	P.B.
	156 gr.	
	No. 218	P.B.
	156 gr.	
	No. 135	G.C.
	156 gr.	
	No. 17	P.B.
	158 gr.	
	No. 28	P.B. B.B.
	158 gr.	
	No. 36	P.B.
	158 gr.	
	No. 27	P.B. B.B.
	158 gr.	
	No. 39	P.B. B.B. G.C.
	158 gr.	
	No. 48	P.B. B.B.
	158 gr.	
	No. 49	P.B. B.B.
	158 gr.	
	No. 52	P.B.
	158 gr.	
	No. 260	P.B.
	158 gr.	
	No. 236	G.C.
	160 gr.	
	No. 51	P.B. B.B. G.C.
	160 gr.	
	No. 64	P.B.
	163 gr.	
	No. 37	P.B. B.B.
	165 gr.	
	No. 56	P.B.
	165 gr.	

.38 Cal. Rev. Cont.

	No. 30 170 gr.	G.C.
	No. 43 173 gr.	P.B. G.C.
	No. 57 175 gr. & 200 gr.	P.B.
	No. 138 200 gr.	P.B.
	No. 127 230 gr.	B.B.



.38-40

	No. 6 180 gr.	P.B.
--	-------------------------	------

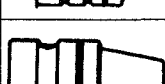
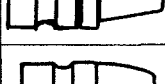
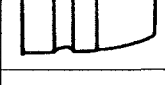

.41 Long Colt

	No. 121 185 gr.	P.B.
--	---------------------------	------





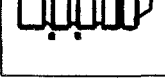





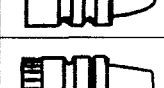

.41 Magnum

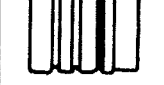
	No. 255 175 gr.	P.B.
	No. 261 200 gr.	P.B.
	No. 253 210 gr.	P.B.
	No. 263 210 gr.	P.B.
	No. 256 210 gr.	P.B. B.B. G.C.
	No. 258 220 gr.	P.B.

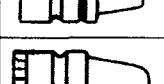
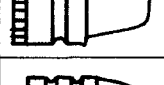

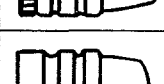
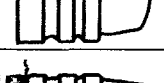

.44 Cal.

	No. 107C 135 gr.	P.B.
	No. 107B 185 gr.	P.B.
	No. 107A 245 gr.	P.B.

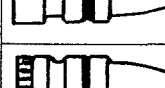

.44 Cal. Cont.

	No. 231 180 gr.	P.B.
	No. 211 200 gr.	P.B.
	No. 237 200 gr.	G.C.
	No. 239 200 gr.	P.B.
	No. 240 200 gr.	G.C.
	No. 241 200 gr.	P.B.
	No. 245 185 gr. P.B. 200 gr. G.C.	P.B. G.C.
	No. 23 205 gr.	P.B.
	No. 44 210 gr. P.B. 250 gr. G.C.	P.B. G.C.
	No. 142 215 gr.	G.C.
	No. 247 220 gr.	P.B.
	No. S140 225 gr.	P.B.
	No. 140 250 gr.	G.C.
	No. 45 240 gr.	P.B. B.B. G.C.
	No. 235 240 gr.	G.C.
	No. 15 240 gr.	P.B. G.C.





.44 Cal. Cont.

	No. 35 240 gr.	P.B.
	No. 503 250 gr.	P.B.
	No. 243 250 gr.	G.C.
	No. 521 260 gr.	G.C.

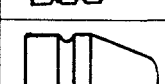
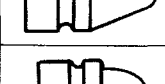

.45 Auto Rim

	No. 193 160 gr.	P.B.
	No. 155 200 gr.	P.B.
	No. 16 230 gr.	P.B.



.45 A.C.P.

	No. 163 185 gr. LINOTYPE	P.B.
	No. 249 185 gr.	P.B.
	No. 229 185 gr.	P.B.
	No. 130 185 gr. LINOTYPE	P.B. B.B.
	No. 519 200 gr.	P.B. B.B.
	No. 68 200 gr.	P.B. B.B.

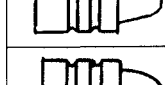
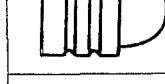

.45 A.C.P. Cont.

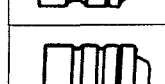
	No. 529 215 gr.	P.B.
	No. 78 215 gr.	P.B. B.B.
	No. 118 215 gr.	P.B. B.B.
	No. 34 230 gr.	P.B. B.B.

.45 A.R. & Long Colt

	No. 21 200 gr.	P.B.
	No. 160 200 gr.	P.B.
	No. 502 240 gr.	P.B.

.45 Long Colt

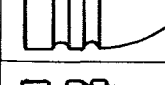
	No. 46 240 gr.	P.B. B.B. G.C.
	No. 59 250 gr.	P.B.
	No. 22 250 gr.	P.B.
	No. 501 250 gr.	P.B.

--- NEW ---

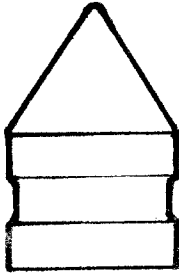

#938

.45 ACP

170 grains linotype

designed by
Dean Grennell

HENSLEY & GIBBS

--- NEW ---
10 mm

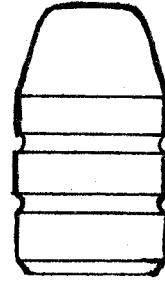

#315

Bren Ten

200 grains.

Adapted from Dornaus & Dixon
design blueprint.

ADDITIONAL BULLET DESIGNS

.25 ACP

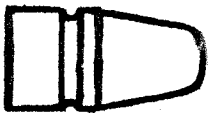

#306 55 grain

Truncated cone

9 mm

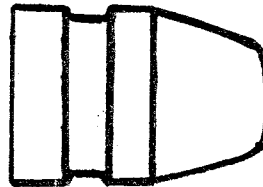

#309 125 grain

Truncated cone.

.45 ACP

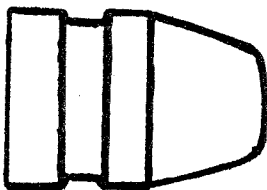

#292 230 grain

Truncated cone.

.45 ACP

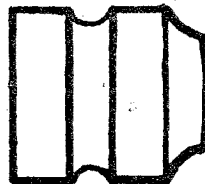

#293 180 grain.

Pheasant/Milam
design.

.45 ACP

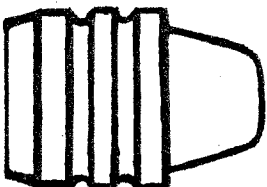

#294 220 grain.

Tapered bevel base.

— PLAIN BASE vs BEVEL BASE —

Several of our designs are available in both plain base and bevel base. The bevel base provides easier starting into case mouth, but when sized in a sizer that has constant hydraulic pressure on the lubricant, this area will fill with grease.

This can be prevented by shaping the bottom punch to cover the bevel area.

Accuracy appears to be the same, with proponents of either type base having excellent theories to back their favorite. In short, if you like to hear debates, ask a few people.

We have had examples sent to us of excellent results with both type bases.

DUE TO FEDERAL REGULATIONS, WE ARE UNABLE TO SHIP SAMPLE BULLETS.

Authentic Elmer Keith bullets are:

38 caliber — #43 44 caliber — #503
41 magnum — #258 45 L.C. — #501

NOTE: #43 and #51 project too far out of case for magnum revolvers that have a short cylinder. For some reason, there are appearing on the market, 357 magnum revolvers with shortened cylinders that will no longer accommodate the #43 and #51 bullets, as they now project too far out of case. Because of this, we now have available #290 which is a #51 with a shortened nose.

NOTE: The S&W model 52 will not accept a #50 bullet, as the nose projects too far out of the case. The bullets listed under ".38 Special Auto" will function properly - we especially recommend #251.

IMPORTANT

To insure receiving a mold most suitable for your needs, specify as much of the following information as possible:

- | | | |
|-------------------------|---|--|
| —4, 6 or 10 cavity mold | —Sizing diameter and make of sizer | —Plain, bevel or gas check base (note: gas checks are not necessary for velocities below 2000 feet per second) |
| —Our bullet number | —Firearm for which bullets are intended | |
| —Alloy to be used | | |

(Although we can usually supply a mold to appropriate size to use without sizing, we recommend the use of a lubri-sizer to assure a round bullet, as alloy content, alloy and/or mold temperatures or any foreign matter between blocks can cause variation in size).

All foreign orders should be pre-paid with either cash sent by registered mail or check drawn in US funds on an American Bank, due to high bank collection fees. **We must declare shipments at full value that go through customs.**

SOLD RETAIL ONLY - DIRECT TO CUSTOMER

— SPECIAL MOLDS —

We can supply bullet designs either shorter or longer than our standard lengths, for an additional \$5.00 per mold.

Also available, molds cut to order, with two or more bullet designs; additional charge of \$5.00 for each extra bullet design after the first.

All special molds, require full payment when order is placed.

— FOLLOWING ITEMS DISCONTINUED —

One and Two Cavity molds, Hollow Point molds, molds for rifle bullets other than those shown.

— COMPLETE REPAIR SERVICE —

If cavity edges are not chipped beyond practical resurfacing, we can recondition most molds of our manufacture. Send complete mold for cost estimate.

METHODS OF PAYMENT FROM OTHER THAN GOVERNMENT AGENCIES

1. **Prepayment:** 20% non-refundable, to be deducted from refund in case of cancellation.
2. **Charge:** 20% non-refundable deposit when order is placed. Remainder to be billed approximately two (2) months prior to shipment.

Your 20% non-refundable deposit guarantees the price you pay will be the price in effect the date you order.

Shipment in approximately 1-5 months.

We do not like being this far behind any more than you do. We hope to gradually shorten the delay, although we've been back-ordered for 15 to 20 years now, but we do keep trying.

We are a very small company, that specializes in bullet molds (with a few pouring ladles thrown in).

Hensley & Gibbs crew has never numbered more than 6 people at any one time since we started making molds in 1934. By intentionally staying small, we have been able to make a product the way we feel it should be made. Unfortunately, this does, of course, limit our production.

Each order is taken in consecutive order, and cut individually to the specification contained thereon.

Each cavity is cherried by hand to finish size, then mold is assembled and tested. The resulting bullets are then checked for diameter and weight. This information is then permanently recorded, along with the cherry used. The mold is serial numbered the same as the order number. By this means, we have a permanent record of its performance.

Our molds cost more (initially), and we can't turn them out rapidly, but we feel the result is a product we are proud to stamp our name on.

HENSLEY & GIBBS

PRICES EFFECTIVE APRIL 12, 1982

Item	4 Cavity SHP WT 3 LBS	6 Cavity SHP WT 5 LBS	10 Cavity SHP WT 7 LBS *Cut for Larger than .38 Cal., Eight Cavities
Complete mold, including sprue cutter & handles , delivered to your area.	\$ 98.50	\$145.00	\$244.00
Surface Mail shipment outside continental U.S.	103.50	150.00	250.00
Airmail shipment outside continental U.S.	120.00	180.00	285.00

Below items usually in stock - Please specify age of mold - parts vary.
Prices below **do not** include shipping and handling.

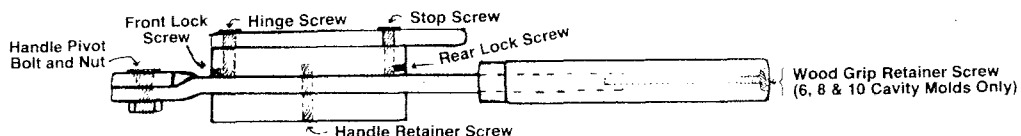

Handles	24.00	36.00	44.00
Sprue Cutter	18.50	21.00	48.00
Sprue Cutter with individual holes	23.50	26.00	-0-
Sprue Cutter hinge screws (each)	1.50	1.50	2.00
Sprue Cutter stop screws (each)	1.50	1.50	2.00
Front or Rear lock screws (in ends of blocks) (pair)	.75	.75	1.00
Handle retainer screws (pair)	1.50	1.75	1.75
Special flush handle retainer screws (pair)	3.00	-0-	-0-
Wood grip retainer screws & washer (pair)	-0-	1.00	1.00
Handle Pivot bolt & nut	1.00	1.50	1.50
Complete set of screws, not including handle pivot & nut	5.00	5.25	6.75
Complete set of screws, complete with handle pivot & nut	6.00	6.75	8.25

WOOD GRIPS

1/4" pilot drilled on end	\$ 1.50 pair
Drilled for 4 cavity handles	2.00 pair
Drilled for 6, 8 & 10 cavity handles	2.50 pair
POURING LADLE	5.00 + Shipping

When ordering above parts, please let us know approximately what year the mold was purchased, since the parts have varied through the years.

NOW AVAILABLE
RUST INHIBITING PAPER
to protect molds during storage.
Four (4) sheets - \$2.00

Four Cavity Sprue Cutters
with individual holes (no trough)
are available for
\$23.50

We can supply alloy flush
HANDLE RETAINER SCREWS
FOR \$3.00 per pair.

HENSLEY & GIBBS BULLET MOLDS DIRECTIONS

1. ALL OIL SHOULD BE CLEANED FROM THE MOLD BEFORE IT IS HEATED. Use gasoline or other solvent. Wipe all solvent from the blocks and cavities. Any residue left on the mold will form carbon. This carbon will cause gas for a long time and prevent the casting of full, sharp bullets.
2. PREHEAT THE MOLD (while the lead pot is heating). Electric or gas hot-plate is suitable. Heat slowly to temperature suitable for alloy being used. It takes too long to bring the mold to proper heat by casting in a cold mold.
3. ALWAYS CLOSE THE MOLD GENTLY. If the heated mold is roughly slammed closed the dowels will be injured and spoil the alignment. While holding the grips firmly rap the mold lightly once on one side. This seats the dowels "home" and prevents alloy from running between partly open blocks. To operate the sprue cutter and to rap the mold closed use nothing other than a light wooden implement.
4. The dowel pins, in a new mold, are quite tight and if mold is over-heated they may bind and not allow the mold to quite close. If the pins seem to stick, and the mold opens with a "snap", close the mold gently, give it a light rap on one side and hold up to the light and observe whether much light shows through between the blocks. (In the larger molds a bit may show without harm as one can see through a very small space when looking against the light.) If the mold is standing open it is only necessary to drive the dowels back into the block very slightly as they are made to be adjusted in this manner. They are so adjusted by us, after heating and testing the mold and this treatment is usually not needed unless the mold is grossly over-heated. As wear occurs the dowels should be driven out a bit to adjust for the wear.
5. Allow time for metal to set and harden and then strike sprue cutter with the wooden mallet. (Here you can tell whether the mold and/or the alloy is at correct casting temperature. If the sprue hardens almost instantly it is too cold. If it takes more than 3 to 5 seconds to harden, then the mold or the alloy is too hot.)
6. After casting for awhile, especially when working fast, the mold blocks may become too hot and, although the metal on sprue cutter appears to have set, upon cutting it off the bullet will be found to be still soft and semi-molten metal dragged across the top of mold. Now, with the bullets still in the cavities (to prevent water getting in) the mold may be quickly plunged into hot water for only an instant. Properly done this will keep the mold at correct casting temperature even when working at top speed. Long, heavy bullets require more time to set than do short light ones.
7. The ratio of mold temperature to temperature of the molten alloy is important. The alloy should be considerably hotter than the mold. If the mold is working too hot, there is less shrinkage in the bullet and it may not fall freely from the cavity. If the mold is cooler and the metal hotter, more shrinkage occurs and the bullet will drop out easier.
8. TO POUR USE ONLY AN OPEN POURING LADLE. Our four, six and ten cavity (8 cavity calibers larger than .38) are all equipped with the fast pouring, trough-type sprue cutter plate. We make a suitable ladle, designed for the purpose. The tube-snout pouring dipper will not pour a stream heavy enough for good results with this type of pouring plate. Pour a good, heavy stream of alloy from a slight height and move the dipper rapidly from one hole to the next. Vary the height of pouring and the speed of progress from one hole to the next one until good results are obtained. With practice, this is the most rapid method of producing good bullets and this is the only method (we have tried them all) that will give consistently good results.
9. It is probably easiest to make good bullets if only new tin and new lead are used for the alloy. However, if scrap lead pipe, plumbers lead or sheet lead is used, usually no trouble will be had. Tin in the form of scrap pipe is good. The local junk dealer is usually the source for these. Linotype metal may be used in place of tin for hardening the alloy. Linotype metal used just as it is makes an excellent rifle bullet alloy. Lead cable covering may be used if the soldered ends are cut off and discarded. A very small amount of this solder (not to be confused with tinner's solder) will spoil a whole pot of alloy. Old storage battery lead may be used to harden the alloy if it does not make the alloy too hard or too large a bullet because of its high antimony content. When lead alloys are repeatedly reheated or when bullets are recovered and used a number of times the alloy becomes short and brittle. This may be mixed with good lead to restore proper hardness.
10. If used frequently and the climate will allow, the mold may not need oiling to protect it from rust. Usually if stored in a wooden container (and not wrapped in cloth or paper) a mold may be left unoiled. This is left to the judgment of the user. Do not use wax, tallow, or anything that cannot be readily cleaned from the mold before heating. Never oil the mold when it is hot.
11. DO NOT TIGHTEN the sprue cutter plate screws so there is any BIND. The plate must be left free to swing of its own weight. Tightening the screws will cause endless trouble by holding the blocks apart and will sooner or later cause either the screws or the plate to break.

12. Do not dump bullets from the mold directly into the pot of molten metal as the splash will cause flakes of metal to cling on the faces of the mold and hold the blocks apart. Lead flakes should be removed, using a sharp knife or razor blade. The flakes should be picked off rather than scraped off so the lead is not rubbed into the mold block.
13. After considerable use, and especially if direction No. 3 is not followed, burrs may form around the dowel holes. This will hold the blocks apart. The burrs may be removed by careful use of a No. 3 cut file.
14. Great care must be used when working on the mold faces so that edges of the cavities are not dulled.
15. If the screw pins that hold the blocks to the handles become worn, they may allow the handle to bear against the bottom of the block slot and cause the mold to stand open on one end. To correct this, remove the handles and observe the worn spot where they bear on the block. File the handle at this point until pressure is restored to center of the block on the screw pin.
16. If mold is allowed to rust, the cavities may be cleaned by revolving a bullet coated with fine grinding compound in each cavity.
17. ABUSE, in the form of the WIRE BRUSH, probably RUINS more molds than any other form of mis-use. NEVER, UNDER ANY CIRCUMSTANCES, USE A WIRE BRUSH on any part of a mold.
18. Every mold is tested by pre-heating and actual use of the mold. The mold then receives final adjustment. The bullets are measured, weighed and are sized. All this is done to determine with certainty that the mold works properly and that the bullets are suitable for intended purpose.

Federal law forbids supplying sample bullets.

We recommend membership in

THE NATIONAL RIFLE ASSOCIATION

1600 Rhode Island Avenue

Washington, D.C.

HENSLEY & GIBBS

P. O. BOX 10
MURPHY, OREGON 97533